

Product name : Proximity / Ambient Light Sensor

Model No. : GP2AP007A00F

1. These technical sheets include materials protected under copyright of Sharp Corporation ("Sharp"). Please do not reproduce or cause anyone to reproduce them without Sharp's consent.
2. When using this product, please observe the absolute maximum ratings and the instructions for use outlined in these specification sheets, as well as the precautions mentioned below. Sharp assumes no responsibility for any damage resulting from use of the product which does not comply with the absolute maximum ratings and the instructions included in these specification sheets, and the precautions mentioned below.

(Precautions)

(1) Please do verify the validity of this part after assembling it in customer's products, when customer wants to make catalogue and instruction manual based on the specification sheet of this part.

(2) This product is designed for use in the following application areas ;

- OA equipment · Audio visual equipment · Home appliances
- Telecommunication equipment (Terminal) · Measuring equipment
- Tooling machines · Computers

If the use of the product in the above application areas is for equipment listed in paragraphs (3) or (4), please be sure to observe the precautions given in those respective paragraphs.

(3) Appropriate measures, such as fail-safe design and redundant design considering the safety design of the overall system and equipment, should be taken to ensure reliability and safety when this product is used for equipment which demands high reliability and safety in function and precision, such as ;

- Transportation control and safety equipment (aircraft, train, automobile etc.)
- Traffic signals · Gas leakage sensor breakers · Rescue and security equipment
- Other safety equipment

(4) Please do not use this product for equipment which require extremely high reliability and safety in function and precision, such as ;

- Space equipment · Telecommunication equipment (for trunk lines)
- Nuclear power control equipment · Medical equipment
- Power generation and power transmission control system (Key system)

(5) Please contact and consult with a Sharp sales representative if there are any questions regarding interpretation of the above four paragraphs.

3. Please contact and consult with a Sharp sales representative for any questions about this product.

1. Application

This technical sheets applies to the outline and characteristics of reflective type proximity /ambient light sensor ; Model No. GP2AP007A00F

2. Outline Refer to the drawing page 5.
 3. Ratings and characteristics Refer to Page 6 to 7.
 4. Supplement

1) This product is built-in photodiode.

2) Brominated flame retardants

Specific brominated flame retardants such as the PBB and PBDE are not used in this device at all.

3) This product shall not contain the following materials.

Also, the following materials shall not be used in the production process for this product.

Materials for ODS : CFCs, Halon, Carbon tetrachloride, 1,1,1-Trichloroethane (Methylchloroform)

4) Compliance with each regulation

4.4.1 The RoHS directive(2011/65/EU)

This product complies with the RoHS directive(2011/65/EU) .

Object substances: mercury, lead, cadmium, hexavalent chromium, polybrominated biphenyls (PBB) and polybrominated diphenyl ethers (PBDE)

4.4.2 Content of six substances specified in Management Methods for Control of Pollution Caused by Electronic Information Products Regulation (Chinese : 电子信息产品污染控制管理办法).

Marking Styles for the Names and Contents of the Hazardous Substances

Category	Hazardous Substances					
	Lead (Pb)	Mercury (Hg)	Cadmium (Cd)	Hexavalent chromium (Cr ⁶⁺)	Polybrominated biphenyls (PBB)	Polybrominated diphenyl ethers (PBDE)
Proximity	○	○	○	○	○	○

This table is prepared in accordance with the provisions of SJ/T 11364.

○ : Indicates that said hazardous substance contained in all of the homogeneous materials for this part is below the limit requirement of GB/T 26572

- 5) Country of origin : China
 6) Product mass : Approx . 0.008 g
 7) The moisture absorption level of this product is MSL.3.

5. Notes

1) Notes concerning receiver surface

Please note enough that it is likely to malfunction when a receiver surface is dirty with garbage and dust, etc. Moreover, please do not touch a receiver surface.

2) For cleaning

Cleaning shall carry out as the below items to avoid keeping solvent, solder and flux on the device.

- Solvent cleaning : Solvent temperature 45°C or less, Immersion for 3 min or less
- Ultrasonic cleaning : Please don't carry out ultrasonic cleaning.
- The cleaning shall be carried out with solvent below.

Solvent : Ethyl alcohol, Methyl alcohol, Isopropyl alcohol

3) Please take proper methods to prevent ESD. The IC built in GP2AP007A00F is ESD-sensitive because it is fabricated by sub-micron CMOS process. For example, in handling GP2AP007A00F, human body and soldering iron etc. should be grounded.

4) Before the circuit design

In circuit designing, make allowance for the degradation of the light emitting diode output that results from long continuous operation. (50% degradation/5 years)

5) Notes ambient light

Proximity mode when set to avoid malfunctions due to a strong disturbance light, such an arrangement to receive ambient light Directly on the detector, please be avoided. Also by placing this product in close proximity to other components, it may be a malfunction with the light reflected from their product, structural arrangement to reduce the amount of light receiving surface of the outer, please consider.

6) After being mounted and soldered, if GP2AP007A00F is deformed by external force or impact, e.g. something falls onto the device, it may result in defective implementation such as lift-off of the terminals. Careful handling should be taken.

7) For soldering

Refer to Page 10.

8) Recommended external circuit

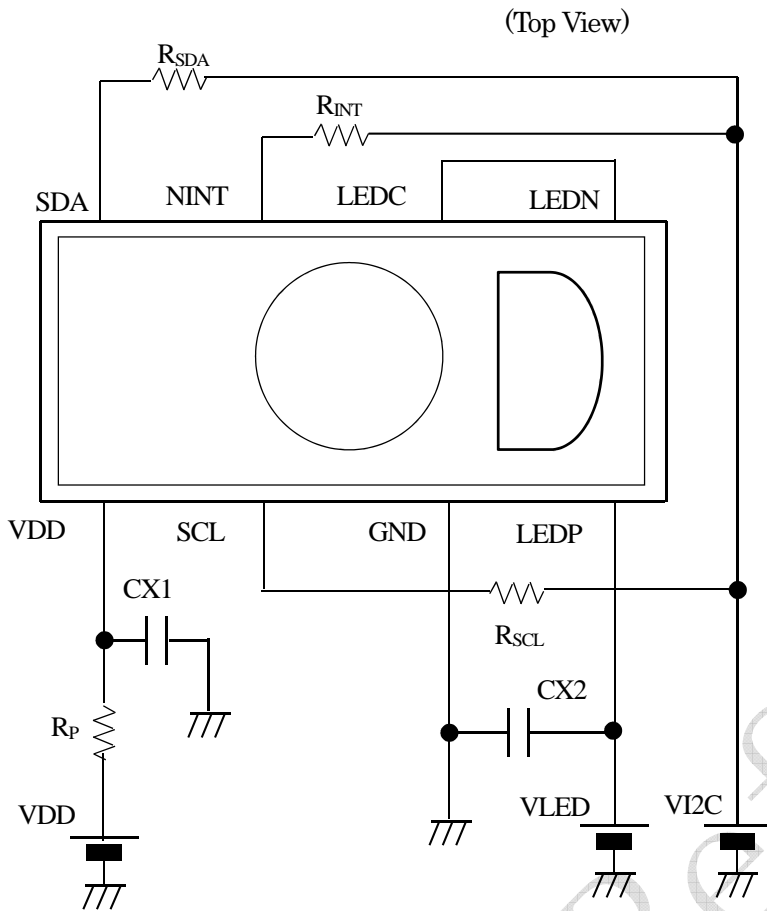

Components	Recommended values
CX1	1 μ F
CX2	2.2 μ F
R _P	22 Ω
R _{SDA}	10k Ω
R _{SCL}	10k Ω
R _{INT}	100k Ω

There are cases to generate a noise because LED driving current flows LEDP terminal, and to distort a waveform of LED driving current.

To reduce these influences, please arrange CX2 within 5mm from LEDP terminal, and wire between LEDP terminal, CX2 and GND terminal as close as possible. Also, the wiring of VLED is separated from VDD and VI2C terminals, and the power source of VLED is separated from VDD is recommended.

And in order to reduce the influence of the power supply noise, please arrange CX1 and R_P within 5mm from VDD terminal.

Please evaluate with the actual electrical implementation, and carefully make sure that there is no problem.

SDA terminal (as output) and NINT terminal are NMOS open-drain output.

9) Block diagram

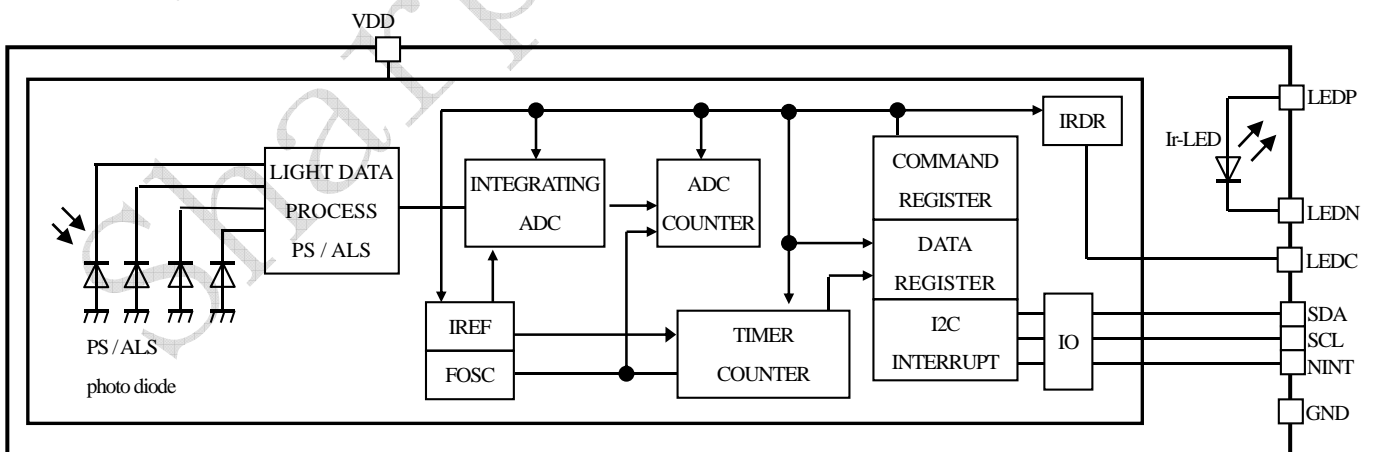

10) Foot pattern of PCB

(1) Dimensions are shown for reference.

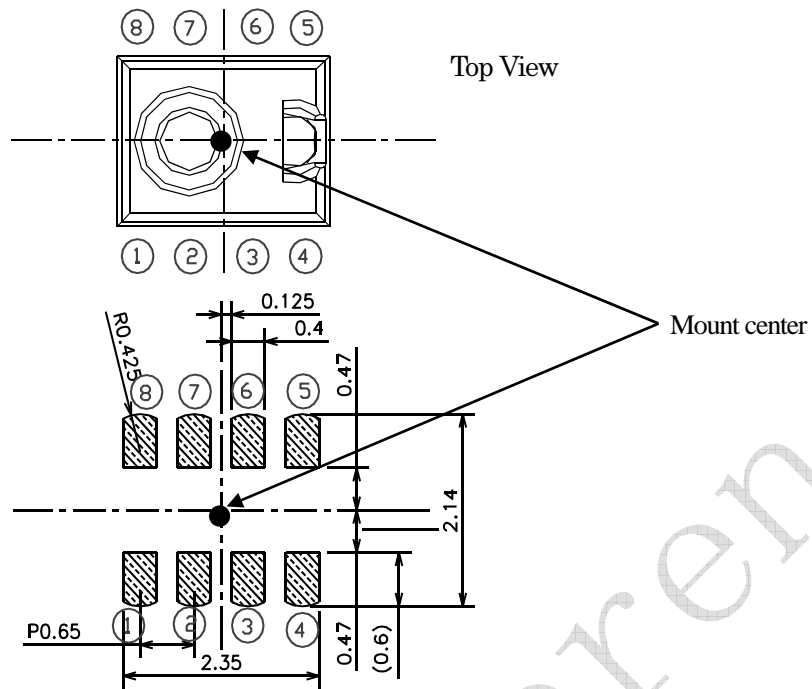

1. Dimension in parenthesis are shown for reference.
2. Unit : mm

Pin	Pin name	Symbol
①	Supply Voltage	VDD
②	I2C Clock	SCL
③	Ground	GND
④	LED Anode	LEDP
⑤	LED Cathode	LEDN
⑥	LED driver	LEDC
⑦	Interrupt	NINT
⑧	I2C Data Bus	SDA

(2) Recommendable size of solder creamed paste (Reference)

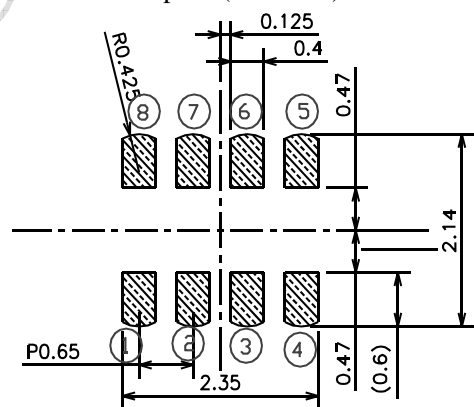

: Soldering paste area
 * Dimensions in parenthesis are shown for reference.
 Unit : mm

2. Outline Dimensions

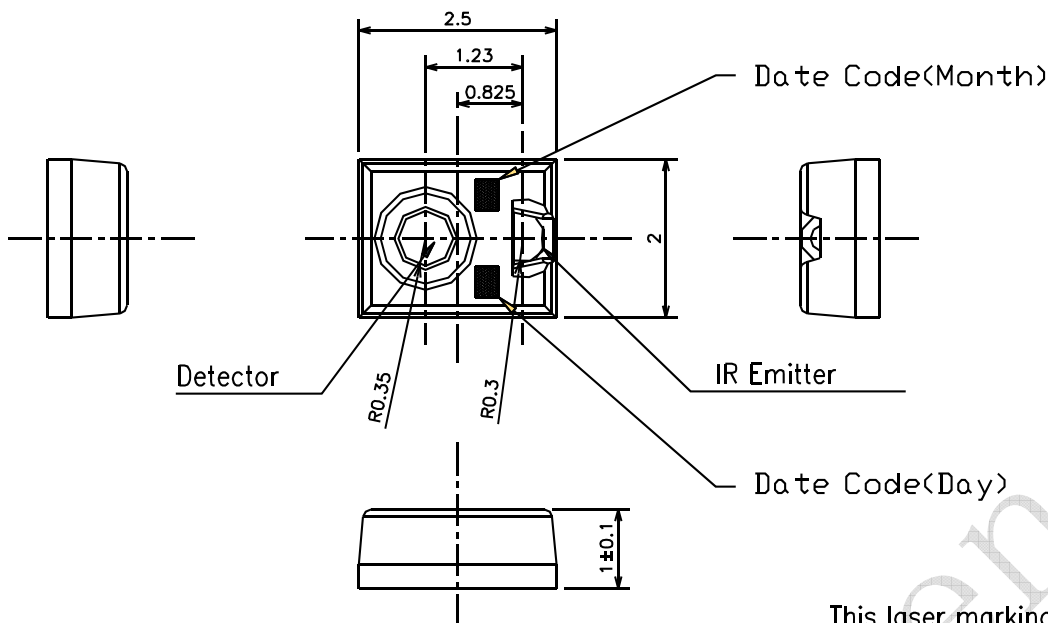

This laser marking means
 Month (1 to 9, X to Z)
 * X to Z = 10 to Z
 Day (1 to 9, A to Y)
 * A to Y = 10 to 31

Charts of the Days

10	11	12	13	14	15
A	B	C	D	E	F
16	17	18	19	20	21
G	H	J	K	L	M
22	23	24	25	26	27
N	P	Q	R	S	T
28	29	30	31		
V	W	X	Y		

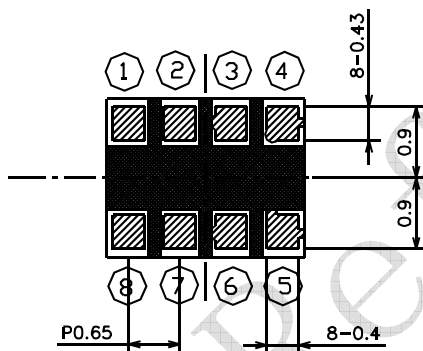

Pin assignment (Top View)

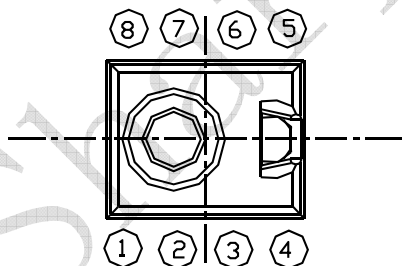

Pin	Pin name	Symbol
①	Supply Voltage	VDD
②	I2C Clock	SCL
③	Ground	GND
④	LED Anode	LEDP
⑤	LED Cathode	LEDN
⑥	LED Driver	LEDC
⑦	Interrupt	NINT
⑧	I2C Data Bus	SDA

- 1) area : Au Plating.
- 2) Unspecified tolerance shall be ±0.2mm.

SCALE	MATERIAL	FINISH	Name	GP2AP007A00F Outline dimension									
10/1	Terminal: Cu	Terminal: Ni, Au											
UNIT	Package: Epoxy resin		DRAWING No.	C	Y	1	5	2	5	4	i	0	2
1 = 1/1mm													

3. Ratings and Characteristics

3.1 Absolute Maximum Ratings

Ta=25°C(unless otherwise specified)

Parameter	Symbol	Rating	Unit	Remarks
Power supply voltage	VDD	-0.3 to 5.7	V	
LED voltage	VLED	-0.3 to 5.7	V	
I2C voltage	VI2C	-0.3 to 5.7	V	
Operating temperature	Topr	-35 to 85	°C	
Storage temperature	Tstg	-40 to 85	°C	
Soldering temperature	Tsol	250	°C	peak temperature duration:10s

3.2 Recommended Operating Conditions

Ta=25°C(unless otherwise specified)

Parameter	Symbol	Operating condition	Unit	Remarks
Power supply voltage	VDD	2.2 to 5.5	V	
LED voltage	VLED	2.2 to 5.5	V	
I2C voltage	VI2C	1.7 to 5.5	V	VDD=5.5V
Operating temperature	Topr	-30 to 85	°C	
SCL, SDA input low level	VIL	-0.3 to 0.54	V	
SCL, SDA input high level	VIH	1.26 to 5.7	V	VI2C=5.5V

3.3 Electrical and Optical Characteristics

Ta=25°C, VDD=VLED=VI2C=3.0V

(unless otherwise specified. The external circuit constants follow the recommended external circuit of page 3.)

Parameter	Symbol	Min.	Typ.	Max.	Unit	Remarks
Current consumption (PS)	ICC_PS		170	250	μA	OP[1:0]=10
Current consumption (ALS)	ICC_ALS		100	150	μA	OP[1:0]=01,RANGE_A=0000
Current consumption (Power Down)	ICC_S	—	—	5	μA	OP[3]=0
Internal Oscillator Frequency	fosc1	1.70	2.13	2.56	MHz	
I2C clock frequency	f	1	—	400	kHz	
SDA output low level voltage	VOL_SDA	0	—	0.4	V	IOL_SDA=3mA
INT output low level voltage	VOL_INT	0	—	0.4	V	IOL_INT=3mA
ADC Conversion Time1 (PS)	Tint_P	—	1.9	—	ms	12bit ADC
ADC Conversion Time1 (ALS)	Tint_A	—	30.8	—	ms	16bit ADC
Full scale ADC code1	Data_FPS	—	—	16383	counts	
Full scale ADC code2	Data_FALS	—	—	65535	counts	
ADCCODE_ALS1	Data_A1	800	1000	1200	Lux	RES_A[1:0]=01, RANGE_A[3:0]=0000 at 1000 lx, White color LED 5200K *1
Detection distance	L	80	100	120	mm	RES_P[1:0]=01,IS[1:0]=11, SUM[2:0]=011, Detection Object : KODAK Gray Card (r=0.9) *2

Ta=25°C, VDD=VLED=VI2C=3.0V

(unless otherwise specified. The external circuit constants follow the recommended external circuit of page 3.)

Parameter	Symbol	Min.	Typ.	Max.	Unit	Remarks
LED peak wavelength	λ_{P_PS}	—	940	—	nm	
LED peak current	I_{LED4}		24	—	mA	IS[1:0]=00
	I_{LED5}		46	—	mA	IS[1:0]=01
	I_{LED6}	—	89	—	mA	IS[1:0]=10
	I_{LED7}	—	164	—	mA	IS[1:0]=11

Typical value is a reference value, there is no guarantee

*1. ALS

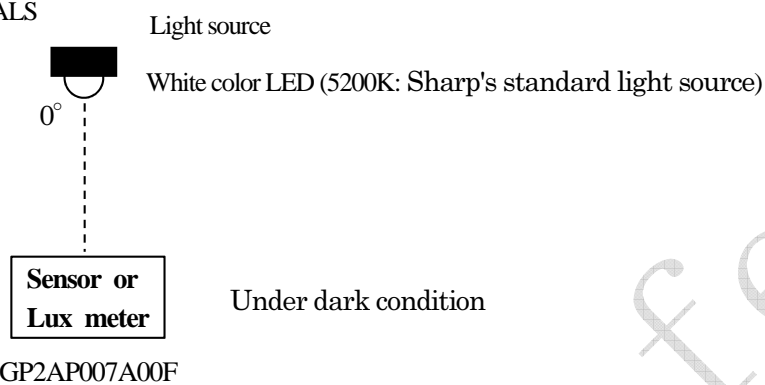

*2. Detection distance (PS part)

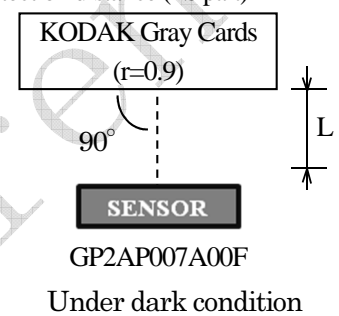

4. Reliability

The reliability of products shall satisfy items listed below.

Confidence level : 90%
LTPD : 10 or 20

Test Items	Test Condition	Failure Judgment Criteria	Samples (n) Defective (C)
* Temperature cycling	1 cycle -40°C(30min) to +85°C(30min) 20 cycles test	$I_{CC_ALS} > U_P \times 1.2$ $I_{CC_PS} > U_P \times 1.2$	n=22, c=0
*High temp. and high humidity storage	+60°C, 90%RH, 240h	$L < L_{ow} \times 0.8$ $L > U_P \times 1.2$	n=22, c=0
* High temp. storage	+85°C, 240h	Data_A1	n=22, c=0
*Low temp. storage	-40°C, 240h	$< L_{ow} \times 0.8$ Data_A1	n=22, c=0
Operation life	+25°C, VDD=VLED=3.0V, IS[1:0]=11, 240h, PS and ALS alternating mode	$> U_P \times 1.2$	n=11, c=0
Mechanical shock	1000m/s ² , 6ms 3 times / ±X, ±Y, ±Z direction	Up: Upper specification limit Low: Lower specification limit	n=22, c=0
Variable frequency vibration	200m/s ² 100 to 2000 to 100Hz/ Approx. for 4min 48 min/ X, Y, Z direction		n=22, c=0
Reflow solder heat	250°C, 10s, twice Temperature profile as shown in page 10.		n=22, c=0

In the test *mark above, the sample to be tested shall be left at normal temperature and humidity for 2h after it is taken out of the chamber. (No dew point)

5. Outgoing inspection

(1) Inspection lot

Inspection shall be carried out per each delivery lot.

(2) Inspection method

A single sampling plan, normal inspection level II based on ISO 2859 shall be adopted.

Parameter	Inspection items and test method		AQL(%)
Major defect	1. Disconnection, short		0.1
	2. Electrical characteristics defect in parameter 3.3		
Minor defect	1. Appearance defect		0.25
	Parameter	Judgment criteria	
	Split, Chip. Scratch Stain, Blur	One which affects the characteristics of Parameter 3.3 shall be defect.	

Precautions for Soldering

1. In case of solder reflow

Reflow is allowed only three at the temperature and the time within the temperature profile as shown in the figure below.

This Profile temperature is the sensor surface package temperature.

Reflow interval shall be within 7days under conditions, 10 to 30°C, 70%RH or less.

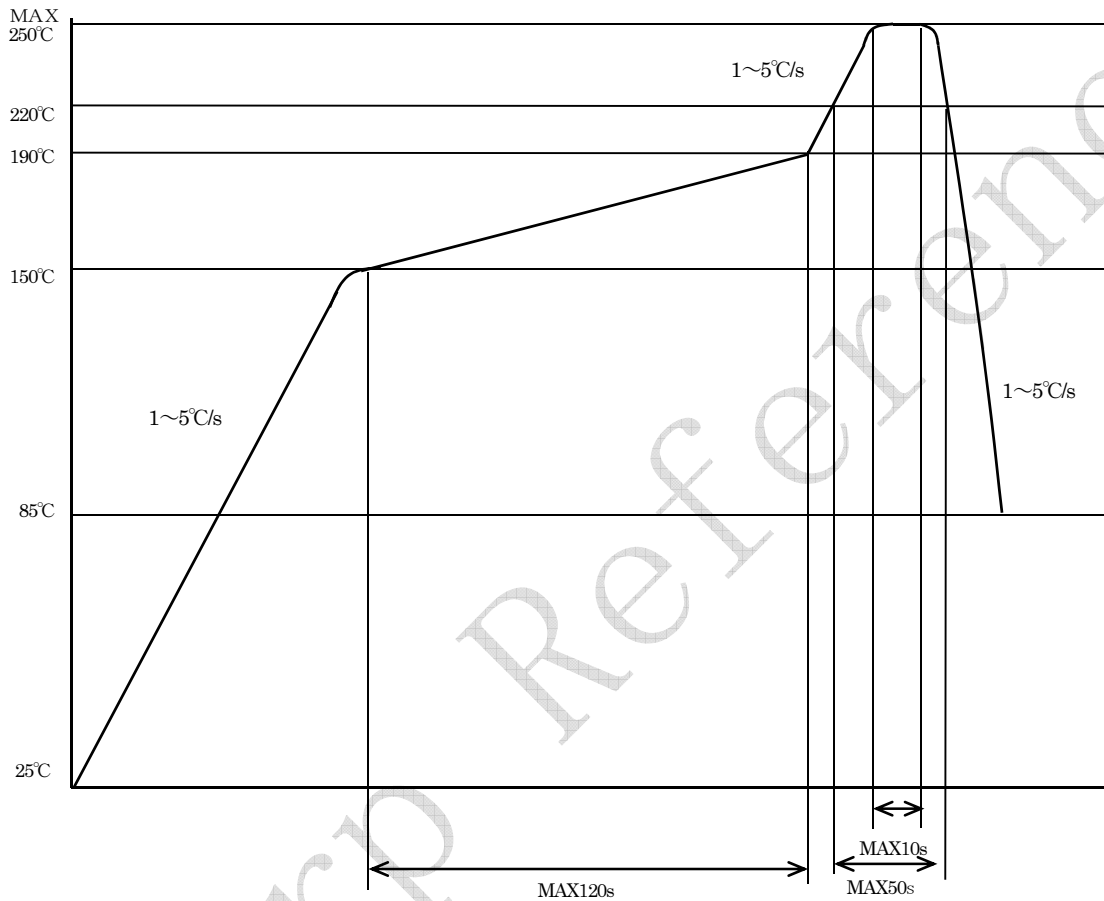

2. Other precautions

An infrared lamp used to heat up for soldering may cause a localized temperature rise in the resin.

Also avoid immersing the resin part in the soldering.

Even if within the temperature profile above, there is the possibility that the gold wire in package is broken in case that the deformation of PCB gives the affection to lead pins.

Please use after confirmation the conditions fully actual solder reflow machine.

Taping specifications

1. Application

This packing specification sheets specify the taping specifications for GP2AP007A00F.

2. Taping method

2.1. Tape structure and Dimensions (Refer to page 12.)

The tape shall have a structure in which a cover tape is sealed pressed on the carrier tape of conductive Polycarbonate.

2.2. Reel structure and Dimensions (Refer to page 13.)

The taping reel shall be conductive plastic with its dimensions as shown in the attached drawing.

2.3. Direction of product insertion (Refer to page 13.)

The sensor direction in carrier tape shall be; the emitter of the sensor locates to the feeding hole side of the carrier tape and the sensor lens faces to the top of the pocket of the carrier tape.

2.4. The way to repair taped failure devices

The way to repair taped failure devices cut a bottom of carrier tape with a cutter, and after replacing to good devices, the cutting portion shall be sealed with adhesive tape.

3. Adhesiveness of cover tape

The exfoliation force between carrier tape cover tape shall be 0.2N to 1.2N for the angle from 160 degrees to 180 degrees.

4. Rolling method and quantity

Wind the tape back on the reel so that the cover tape will be outside the tape. Attach 16cm or more of blank tape to the trailer and 40cm or more of blank tape to the leader and fix the both ends with adhesive tape.
One reel shall contain 2000pcs. Except for the case that device is removed. There must not be continuously two or more Stock-Outs.

5. Safety protection during shipping

There shall be no deformation of component or degradation of electrical characteristics due to shipping.

6. Surface resistivity

Name	Surface resistivity (Ω/\square)	Material
Carrier tape	1×10^4 to 1×10^8	Electroconductive polycarbonate
Cover tape	1×10^4 to 1×10^7	Electroconductive polyester
Reel	Less than 1×10^9	Poly phenylene ether

7. Tape and Real structures

7.1 Tape structure and Dimensions

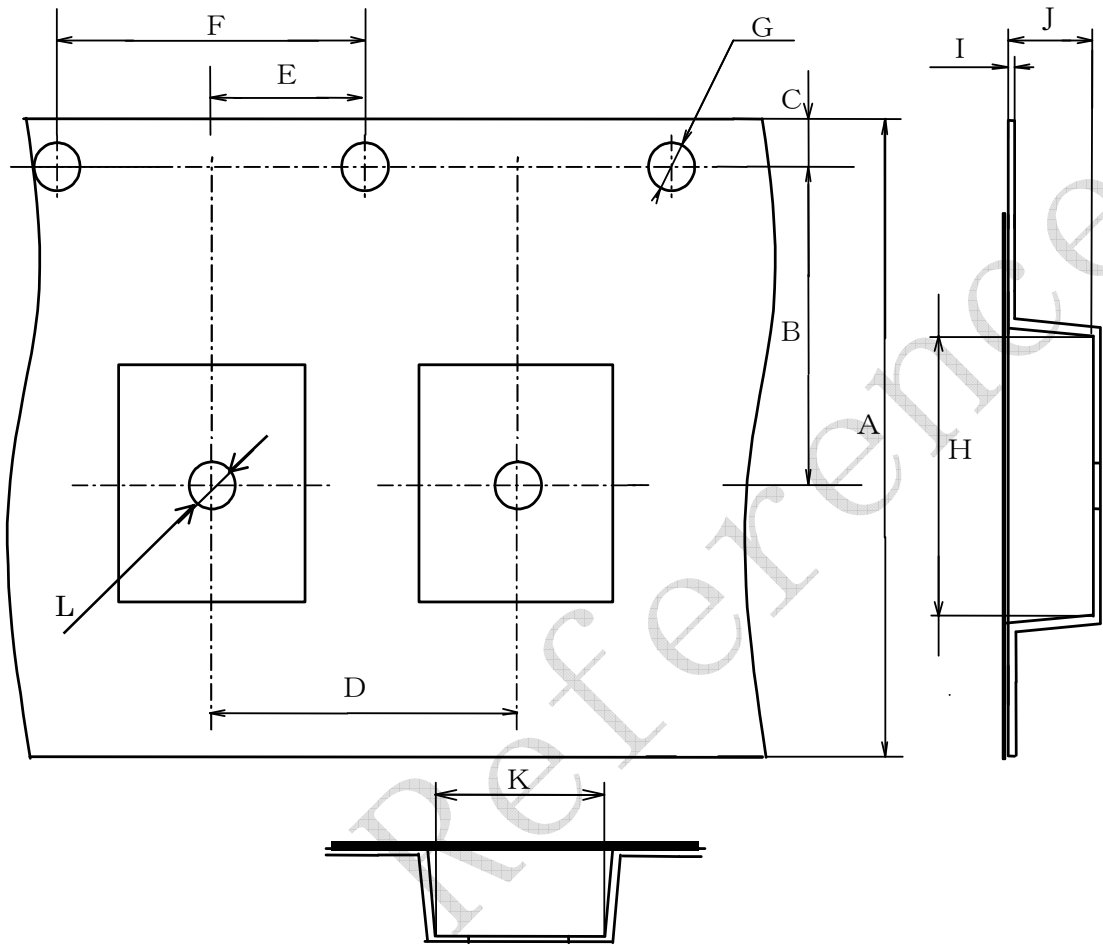

Symbol	A	B	C	D	E	F
Unit						
mm	± 0.1 12.0	± 0.05 5.5	± 0.1 1.75	± 0.1 4.0	± 0.05 2.0	± 0.1 4.0

Symbol	G	H	I	J	K	L
Unit						
mm	$\begin{matrix} +0.1 \\ -0.0 \\ \phi 1.5 \end{matrix}$	± 0.1 2.8	± 0.05 0.25	± 0.1 1.3	± 0.1 2.3	± 0.1 $\phi 1.0$

7.2 Reel structure and Dimensions

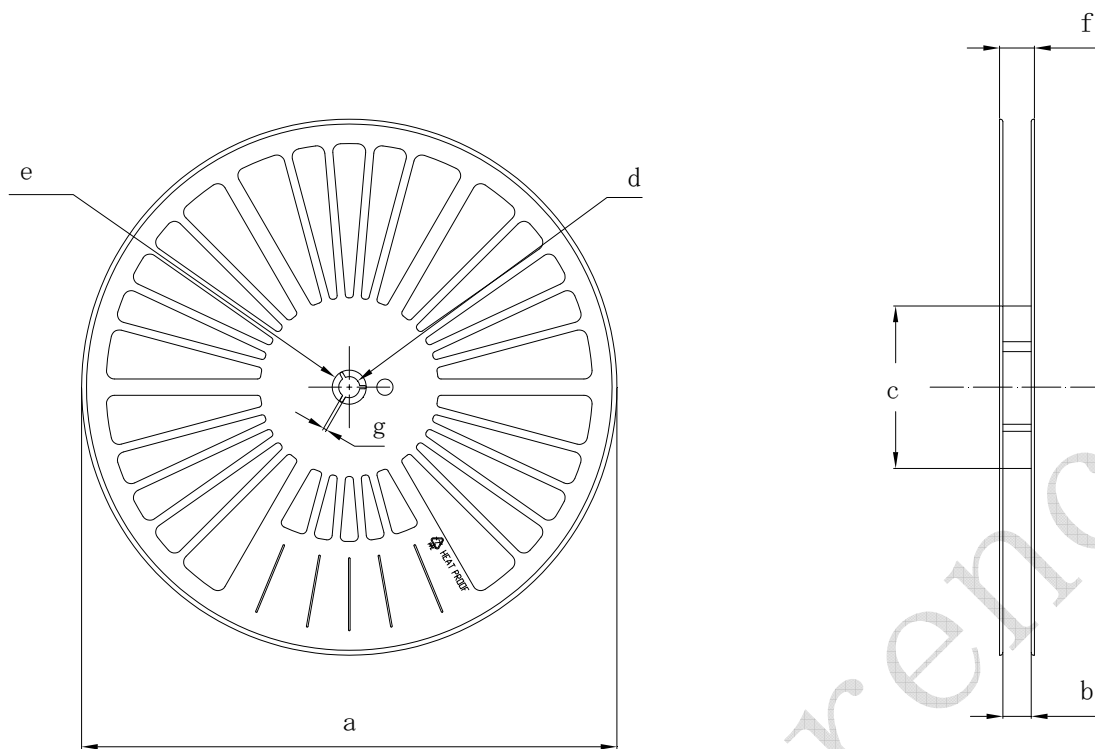

Symbol Unit	Check word						
	a	b	c	d	e	f	g
mm	$\phi 180 \pm 2.0$	13.5 ± 1.0	$\phi 60 \pm 1.0$	$\phi 13 \pm 0.2$	$\phi 21 \pm 0.8$	17.1 ± 1.0	2 ± 0.5

7.3 Direction of product insertion

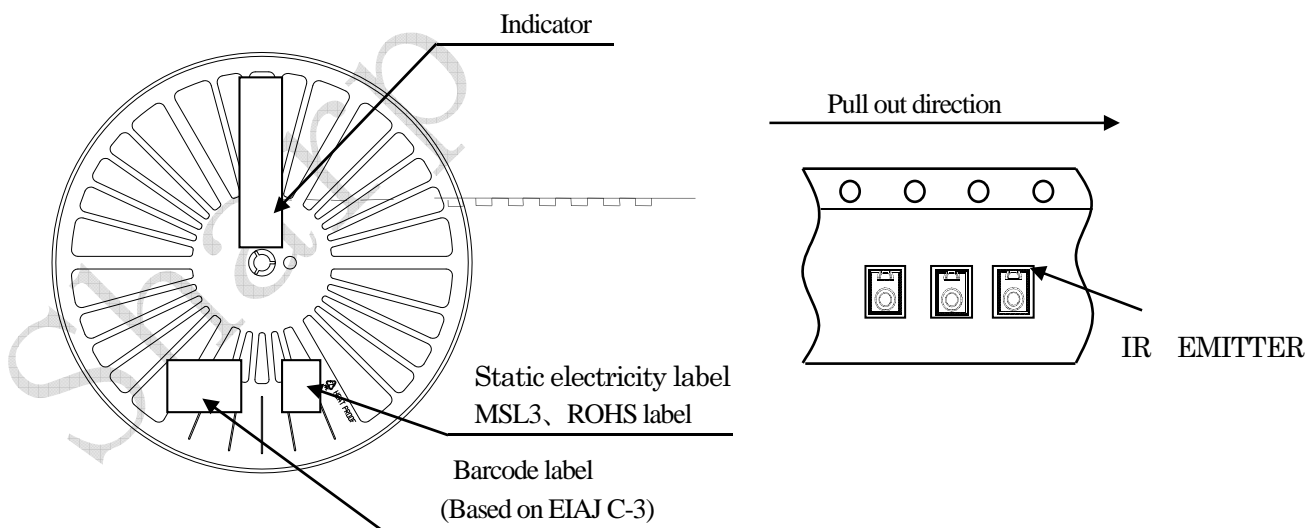

Taping moisture-proof packing

1. Application

This packing specification sheets apply to the moist-proof packing for the GP2AP007A00F in the taping package.

2. Packaging specifications

2.1 Packaging material

Name	Material	Counter measure for ESD	Quantity
Aluminum laminate bag	Aluminum polyethylene	Conductive type	Refer to 2.2
Label	Paper(-made)	Non	
Siccative	-	Non	
Packing case	Paper	Non	
Cushioning material	Urethane	Non	
Indicator	Paper	Non	

2.2 Packaging method

- (1) Fill necessary information to barcode labels.
- (2) Paste one of the barcode labels and a moisture indicator to a tape reel (contains 2,000 devices per reel).
- (3) Seal the aluminum laminated bag that contains the tape reel and siccative, and paste one of the barcode labels.
- (4) Pack 5 aluminum laminated bags (contains 1 reel each) into the designated packing case, where Urethane cushioning material are placed on the top of the packing case.

Package shape	Product	Quantity	Moisture-proof sack Quantity
Tape reel (φ 180mm)	1 model	2000pcs. / reel *	1 reel / laminated bag

Minimum order/shipment quantity should be 1 laminated bag.

- (5) The packing case would be then sealed with the craft tape, with barcode label (based on EIAJ C-3).
(Total of 10,000pcs. per carton) * Except for the case that device is removed.

3. Storage and Treatment after Unsealed

3.1 Storage conditions The delivered product should be stored with the conditions shown below;

Storage temperature : 10 to 30°C

Humidity : below 70%RH

The warranty term for the shipped product shall be for 1 year after shipping to the designated place by the ordered customer.

3.2 Treatment after open

- (1) After unsealed, devices should be mounted under the temperature condition of 10 to 30°C, at the humidity condition of below 70%RH, within 7days.
- (2) In case that long term storage is needed, devices should either be stored in dry box, or re-sealed to moist-proof bag with siccative and leave them in the environment where the temperature is 10 to 30°C, at the humidity condition of below 70%RH. Devices must be mounted within 2 weeks.

3.3 Baking before mounting

In the event that the devices are not maintained in the storage conditions described above, or the enclosed siccative indicator already turned its color to pink, baking must be applied before devices are to be mounted.

The case that Devices was not mounted under the temperature condition of 10 to 30°C at the humidity condition of below 70%RH or lower within 7days, Baking process must be applied before devices are to be mounted.: Please also note that baking should only be applied twice.

Recommended condition : ①100 to 110°C, 12 to 24 hours ②125°C, 6 to 24hours

※ Baking will not properly done in packing condition.

To complete the baking properly, devices should be placed to the metal tray.

Recommended condition of reel baking : 125°C, 6 to 24hours

※ In the case of reel baking, hung the reel in the oven by passing the shaft in the center hole of reel.

Please avoid laying the reel.

3.4 Placement of reels in an oven

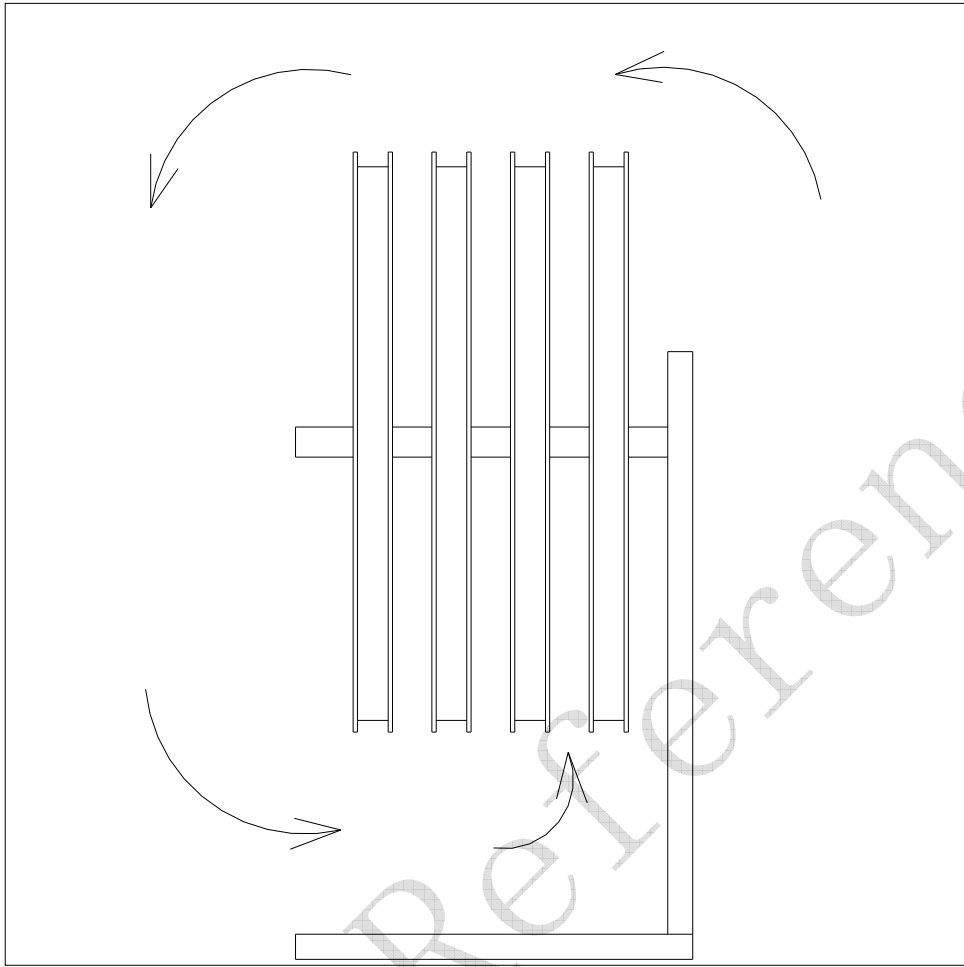

- 1) Please hang reels by using a center hole for fixing the reel.
Please keep some space between reels for better air rotation in the oven.
Please do not lay a reel down in the oven to avoid any damages for the tape edge and the flange of reel.
- 2) Please make sure the carrier tape does not have any slack in a reel before baking to avoid peeling the cover tape off.
Since the tape using for fixing carrier tape is not heatproof, there is a case to remain glue.
So if necessary, please change the tape to a heatproof one.

4.Packing

Inner Packing

① Inner Packaging drawing

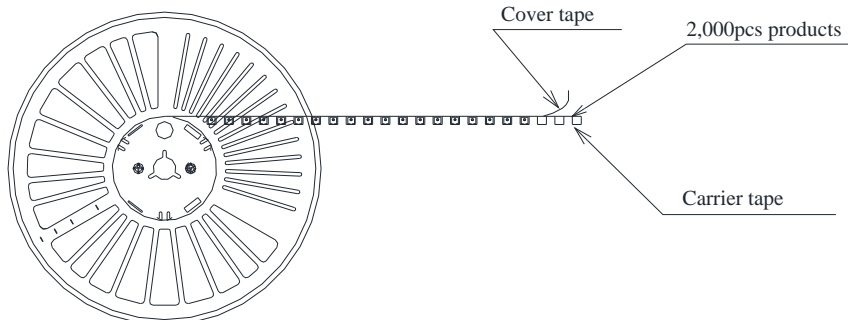

- ② Inner packing material: • Reel(PPE) • Carrier tape (PC) • Cover tape(PET)
- ③ Quantity :2,000pcs./Reel

Outer Packaging

① Outer Packaging drawing

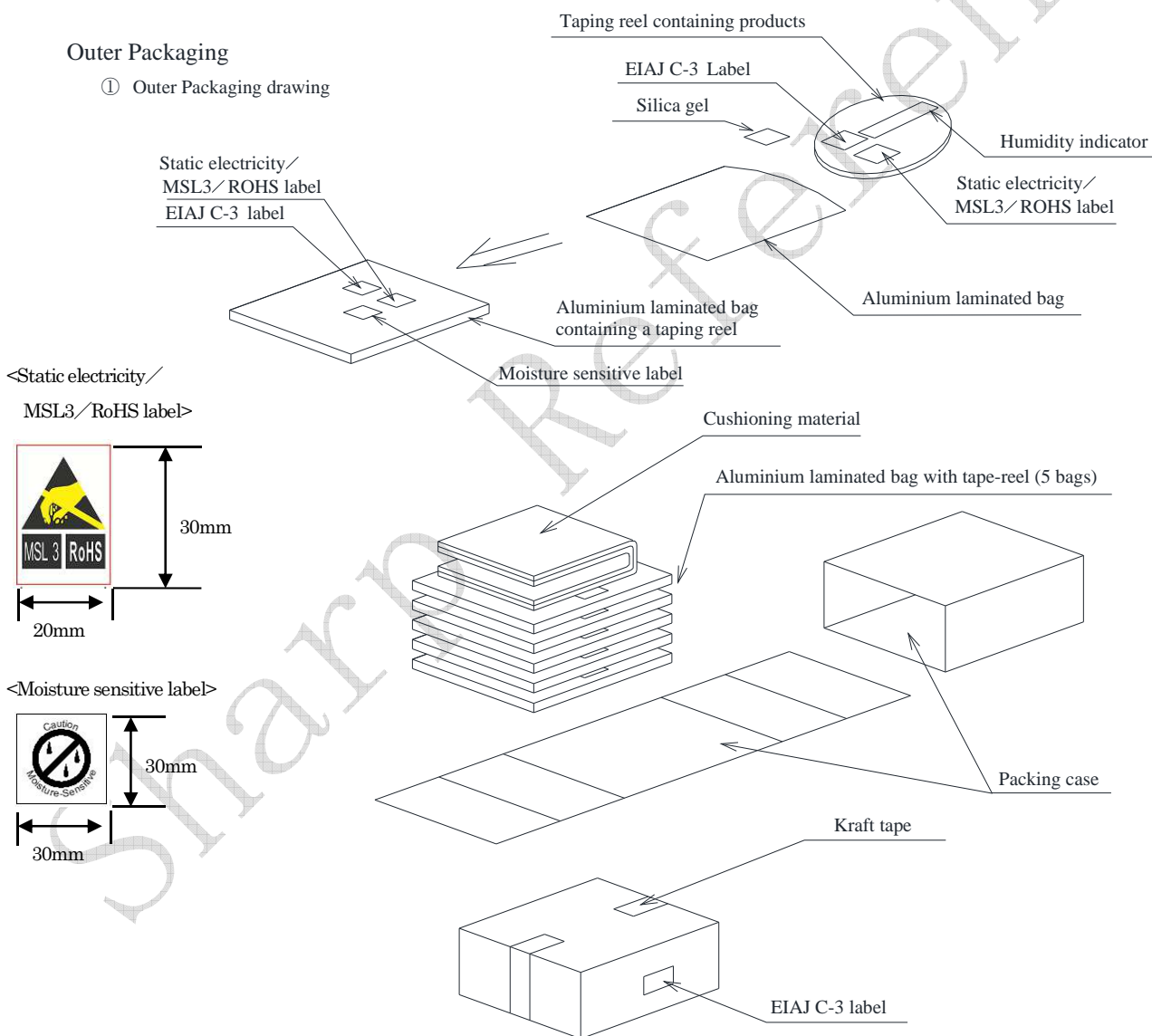

- ② Outer packing material: Packing case(Corrugated cardboard), Cushioning material (Urethane)
Aluminium laminated bag (Alumi-Polyethylene)
Humidity indicator card (paper), Label(paper), Silica gel, Craft tape
- ③ Quantity: 10,000pcs./box
- ④ The contents of the carton indication conforms to EIAJ C-3 and the following items are indicated.
Model No., Internal production control name, Quantity, Packing date, Corporate name, Country of origin
- ⑤ Regular packaged mass: Approximately 700g